



**An ISO Certified Company**

ISO 9001:2015 | ISO 14001:2015 | ISO 45001:2018



*Powering Progress*

# **KLR TRANSFORMERS**

We can cater the needs of all small, medium & large-scale industries up to 132 KV class 80 MVA is the present top limit, Extendable to 220 KV Class in coming years.

## Management Team



**K. Linga Reddy**  
Chairman

K. Linga Reddy with **50 Years** of experience in Transformers Industry.

“ Quality in a service or product is not what you put into it. It is what the client or customer gets out of it.



**K. Ravi Krishna Reddy**  
Managing Director

K. Ravi Krishna Reddy with **25 Years** of experience in all vistas of transformer manufacturing, honed under the tutelage of the Chairman.

Customer may be choosy but not we, every customer at all levels are served by us, satisfied customers are frequently seen at our premises, that is our pride and promise all these years. Customer satisfaction is the mandate with our activity, striving for excellence is a habit with our people, that is our human resource policy.

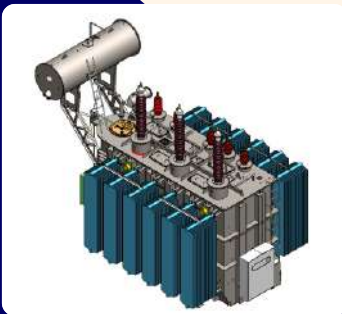

## 3D Design Facility

## Design Office & Engineering Facility



### Our Vision

Promote an indigenous manufacturing unit and to grow to global scale operations in Powers sector.



### Our Mission

Power the worlds progress, enabling economic growth through innovation and create sustainable future and enhance customer satisfaction.



### Core Values

**Integrity** - Always keep it in every work

**Innovation** - Creative in our Work

**Accountability** - Own it, and express it always

**Adaptability** - Have an Innovative mind to adapt to new ideas

**Simplicity** - Keep it simple and comprehensive

**Loyalty** - Built on trust, and continuity



### Our Strength

- o Experience Team over decades.
- o State-of-the-art manufacturing facilities
- o Skilled workforce with training backup
- o Automated Testing and validation with minimum manual intervention
- o Strong supply chain management
- o Comprehensive customer support after sales



### Business Philosophy

- o Growth through expansion
- o Customer feedback and analysis
- o Continuous improvement
- o Profit accrued through efficient working
- o Do it right first time & every time

## Infrastructure



**Foil & strip Winding Machines in dust free area**



**Copper Punching, Cutting & Bending Machine**



**Automated Vacuum Ovens**



**Dust Proof Winding Section**



**ETO Cranes (80,20,10,5 tonne)**

## Products - BIS Approved Products up to 2500 kVA (BIS Licence No: 6300121586)



**Power Transformers**  
Up to 80MVA, 132KV Class



**Inverter Duty transformer**  
Multi windings up to 18MVA, 33KV class



**Distribution Transformer**  
250KVA to 2500KVA up to 33KV Class  
as per BIS Standards



**Induction Furnace & Arc Furnace Transformers - Up to 30MVA, 33KV Class**



**Wind Power Transformers**  
Up to 6.5MVA, 33KV class



**Dry Type Transformers**  
Up to 2500KV, 33KV Class



**Compact Substations**



**Corrugated Transformer**



**Pad Mounted Transformers**

## Service Capability

KLR provides comprehensive transformer service to ensure that your transformer operate at optimum performance.

### The following service activities provides

1. Refurbishment services are available including rewinding of transformers of any make up to 80MVA, 132KV class.
2. Erection, Commissioning and Overhauling of all types of oil cooled transformers.
3. Offers Annual maintenance on site contact for oil cooled transformers of any make.
4. On-site servicing, Reconditioning, Stand-by and Testing of transformers of any make.

## Automated Testing Facility

1. Full-fledged automated In house testing facility to carry out all routine and type tests, conforming applicable standards.
2. All the transformers are tested at the manufacturing test facility prior to shipment.
3. Dynamic short circuit type test can be performed at central power research institute (CPRI) or third party Independent NABL accredited laboratory.



## Contact Us

### Office :

H.No-2/40, Plot No - 13 & 14, Survey No- 06, Ramabhoopal Chambers, Ground Floor, Izzat Nagar, Kondapur, Hyderabad - 500084.

### Factory :

Plot No - 290/C, IDA, phase - 3, Pashamyalam, Hyderabad - 502307  
[www.klrtransformers.com](http://www.klrtransformers.com)

### Phone :

+91 - 9642004300

### General Enquires :

[marketing@klrtransformers.com](mailto:marketing@klrtransformers.com)

### Purchase :

[sivaji.v@klrtransformers.com](mailto:sivaji.v@klrtransformers.com)

### Phone :

+91 - 9121865819